

SECURITY BARRIERS

EB950CR Armstrong

Avon EB950CR Armstrong Security Barriers provide a high level of protection where central roadway foundations are not possible / practical.

The EB950CR is a traditional looking control barrier with the benefits of high level physical protection.

Independently physically tested in a number of full scale crash tests conducted in accordance with PAS 68 by the Transport Research Laboratory (TRL). The EB950CR is an electro-hydraulically operated rising arm barrier with arm widths of up to 4.5m span .

The EB950CR offers an optional locking system that can be retrofitted to the end of the boom. This modification has undergone additional IWA 14-1 testing using an 1500Kg (M1) saloon car traveling at 30mph. It also successfully passed the CPNI VADS (Vehicle Access Delay Standard) testing which provides assurances that it is capable of withstanding repetitive nudging and ramming to gain access.



Member of Perimeter Protection Group

t: +44 (0) 117 953 5252

e: sales@avon-barrier.com

w: www.avon-barrier.com



PRODUCT SPECIFICATION

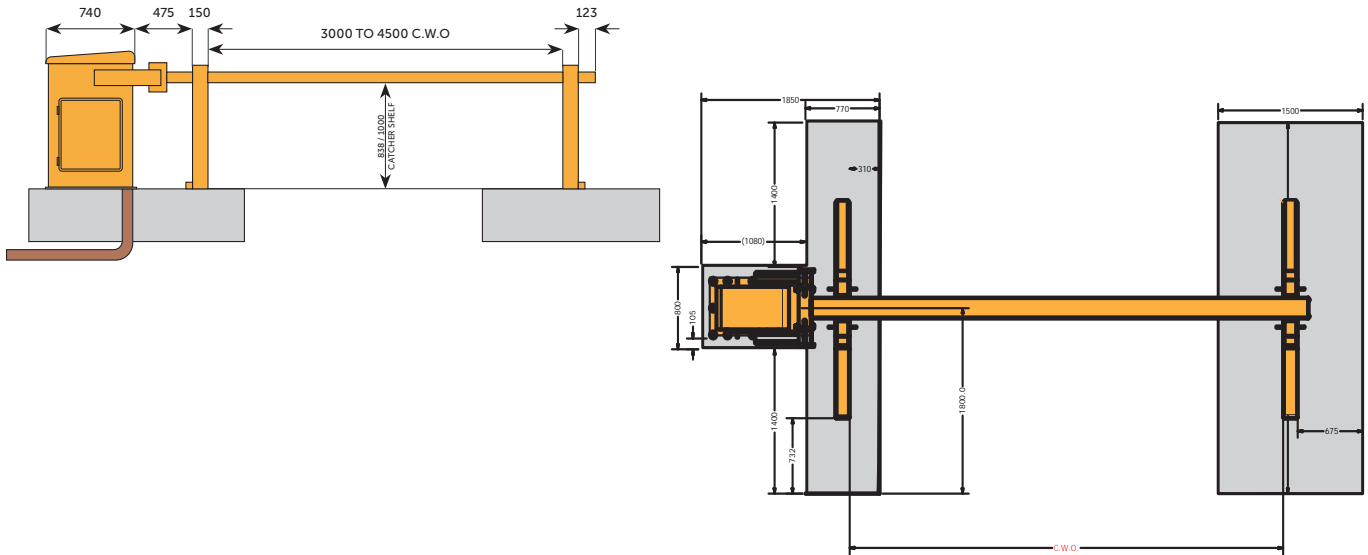

FEATURES

- » Physically impact tested to PAS 68 & IWA 14-1 criteria
- » Shallow mounting from 450mm overall depth
- » Manufactured from heavy gauge materials
- » Manual hand pump facility
- » Programmable controller
- » 100% duty cycling

BENEFITS

- » Confidence in proven performance
- » Overcomes site depth restrictions
- » Strong and durable
- » Operational under power failure conditions
- » Flexibility to interface with all forms of access control
- » Reliable and dependable

Physical Dimensions:

Barriers Arm - 5m max
 W - 600mm | D - 890mm | H - 1230mm
 Barrier Catcher Foundations
 W - 1500mm | D - 3600mm | H - 470mm

Basic Power Requirements:

Single phase 220v AC, 50Hz, Min 16 Amps
 (dependent on configuration)

Control Voltage:

S.E.L.V 24v

Impact Absorption

723KJ (fully operational immediately after impact)

PAS 68 Classification:

V/7500(N2)/48/90:0.0/0.0

IWA 14-1 Classification:

V/1500(M1)/48/90:1.9

VADS Classification:

Pass

Tested Model:

1m H x 3m W

Speed of Operation:

6 - 10 Seconds to raise or lower

Operating temperature range available (option):

-25°C - +70°C

OPTIONS AVAILABLE

- » VADS locking mechanism
- » Access and intercom systems
- » Emergency buttons with lock down
- » Integral inset warning lights
- » UPS backup for the electrical system
- » Interlocking systems to give air-lock type protection on sites with higher threat levels
- » Inductive loop systems
- » Traffic lights and back-indications systems
- » Interlocking systems to give air-lock type protection on sites with higher threat levels
- » Inductive loop systems
- » Traffic lights and back-indications systems